



Combi2™ TTW®

Residential Energy Saver Power Vent Combi2™ Gas Water Heater System



Photo is of
C-DW2-TW50T10FBN

The Combi2™ TTW® FVIR Defender Safety System® Models Feature (50 gallon model, only):

- **Advanced ScreenLok® Technology Flame Arrestor Design**—Flame arrestor is designed to prevent ignition of flammable vapor outside of the water heater.
- **Flammable Vapor Sensor**—Electronic sensor prevents burner operation if flammable vapors are detected. The sensor will also prevent operation if there is ongoing flammable vapor burn inside the combustion chamber.
- **Maintenance Free**—Regular cleaning of air inlet openings or flame arrestor is not required under normal conditions.
- **Sight Window**—Offers a view of the pilot and burner operation.
- **Pedestal Base**—Rugged and durable base allows easy transport and positioning, and provides corrosion resistant contact with floor.
- **Stainless Steel Flue Baffle**—Designed to maximize the amount of heat absorbed in the lower portion of tank.

All Combi2™ TTW® Models Feature

- **Heat Exchanger**—Double wall 1½" O.D. glass coated (Vitraglas®) steel coil ensures separation of potable water and heating fluid.
- **Low Heat Exchanger Head Loss**—Up to 10 GPM flow, with less than 5 ft. of head loss. Greatly reduces the required pump size for heat exchange.
- **Powerful Blower Motor**—Our design has higher torque for greater resistance to outside winds and the power to eliminate problems with difficult venting situations. This significantly quieter motor runs cooler for a considerably longer operational life.
- **Spark to Pilot Ignition System**—Eliminates the constant burning pilot used on other water heaters.
- **Horizontal and Vertical Venting**—With 3" or 4" PVC, ABS OR CPVC (Maximum equivalent vent length on reverse side).
- **Electronic Gas Control Valve**—The integrated, immersion gas control valve offers more precise temperature control for higher first hour delivery and also allows water temperature adjustment without removing the cover. The control is equipped with an LED display to aid in start-up and diagnostics.
- **Vitraglas® Lined Tank**—Bradford White water heater tanks are protected from the corrosive effects of hot water by an exclusive ceramic porcelain-like coating.
- **Steel Tank**—Heavy gauge steel automatically formed, rolled and welded to assure a continuous seam for glass lining.
- **Thermostatic Mixing Valve**—Supplied to help prevent injury due to scalding.
- **Protective Aluminum Anode Rod**—Provides added protection against corrosion for long trouble-free service.
- **Factory installed Hydrojet® 2™ Total Performance System**—Cold water inlet sediment reducing device. Helps prevent sediment build up in tank. Increases first hour delivery of hot water while minimizing temperature build up at top of tank.
- **Water Connections**—¾" NPT factory installed true dielectric fittings.
- **2" Non-CFC Foam Insulation**—Covers the sides and top of tank to save energy by retarding loss of heat. Also increases jacket rigidity.
- **T&P Relief Valve**—Installed.
- **Brass Drain Valve.**
- **Design Certified by CSA International (formerly AGA and CGA).**



10-Year Limited Tank and Heat Exchanger Warranties / 6-Year Limited Warranty on Component Parts.

For more information on warranty, please visit www.bradfordwhite.com

For products installed in USA, Canada and Puerto Rico. Some states do not allow limitations on warranties. See complete copy of the warranty included with the heater.

Bradford White received the highest numerical score among water heater/boiler manufacturers in the proprietary J.D. Power and Associates/ McGraw-Hill Construction 2006 HVAC and Water Heater/Boiler Subcontractor Satisfaction Study™. Study based on 882 responses measuring 3 water heater/boiler manufacturers and measures opinions of subcontractors. Proprietary study results are based on experiences and perceptions of subcontractors surveyed in May through July 2006. Your experiences may vary. Visit jdpower.com

MANUFACTURED UNDER ONE OR MORE OF THE FOLLOWING U.S. PATENTS: 7,063,133 B2; 5,954,492; 5,761,379; 5,943,984; 5,081,696; 5,988,117; 6,142,216; 5,199,385; 5,574,822; 5,372,185; 5,485,879; 5,277,171; (B1)5,341,770; 5,660,165; 5,596,952; 5,682,666; 4,904,428; 5,023,031; 5,000,893; 4,669,448; 4,829,983; 4,808,356; 5,115,767; 5,092,519; 5,052,346; 4,416,222; 4,628,184; 4,861,968; 4,672,919; Re. 34,534. OTHER U.S. AND FOREIGN PATENT APPLICATIONS PENDING. CURRENT CANADIAN PATENTS: 1,272,914; 1,280,043; 1,289,832; 2,045,862; 2,112,515; 2,108,186; 2,107,012; 2,092,105. Defender Safety System®, ScreenLok®, TTW®, Vitraglas® and Hydrojet® are registered trademarks of Bradford White® Corporation. ©2006, Bradford White Corporation. All rights reserved. Printed in U.S.A.

Combi2™ TTW® Through-The-Wall Gas Water Heater



Deluxe Energy Saver Models

NATURAL GAS AND LIQUID PROPANE GAS

Meet or exceed ASHRAE 90.1b (current standard) C.E.C. Listed
80% Recovery Efficiency

Model Number	Capacity				Recovery 90°F Rise*				A	B	C	D	E	F	G	H	J	K	Approx. Shipping Weight
	U.S. Gal.	Imp. Gal.	Nat. BTU/Hr. Input	LP BTU/Hr. Input	Nat. U.S. GPH	Nat. Imp. GPH	LP U.S. GPH	LP Imp. GPH	Floor to Vent Conn. in.	Jacket Dia. in.	Vent Size in.	Floor to T&P Conn. in.	Floor to Gas Conn. in.	Floor to Exchanger Inlet in.	Floor to Exchanger Outlet in.	Floor to Heater Top in.	Floor to Water Conn. in.	Depth in.	
C-DW2-TW50T10FBN	45	38	67,000	60,000	72	60	65	54	65%	22	3	50%	11%	28	50%	56%	57%	26%	245
C-DW2-TW75T10BN	72	61	76,000	75,500	82	69	81	67	69%	26	3	53	15	30%	53	60%	61%	31	335

Model Number	Capacity				Recovery 50°C Rise*		A	B	C	D	E	F	G	H	J	K	Approx. Shipping Weight
	Liters	kW Input	Nat. kW Input	LP kW Input	Nat. Liters/Hour	LP Liters/Hour	Floor to Vent Conn. mm.	Jacket Dia. mm.	Vent Size mm.	Floor to T&P Conn. mm.	Floor to Gas Conn. mm.	Floor to Exchanger Inlet mm.	Floor to Exchanger Outlet mm.	Floor to Heater Top mm.	Floor to Water Conn. mm.	Depth mm.	
C-DW2-TW50T10FBN	170	19.6	17.5	272	246	1673	559	76	1273	298	711	1273	1432	1467	679	111	
C-DW2-TW75T10BN	272	22.3	22.1	310	306	1772	660	76	1346	389	784	1549	1530	1562	787	152	

All Propane heaters are equipped with a cast iron burner. To order a Propane heater change suffix "BN" to "CX".

*Based on manufacturers rated recovery efficiency.

110 V.A.C Required for Power Venting / 110 V.A.C., 60HZ, 3.1 Amperes

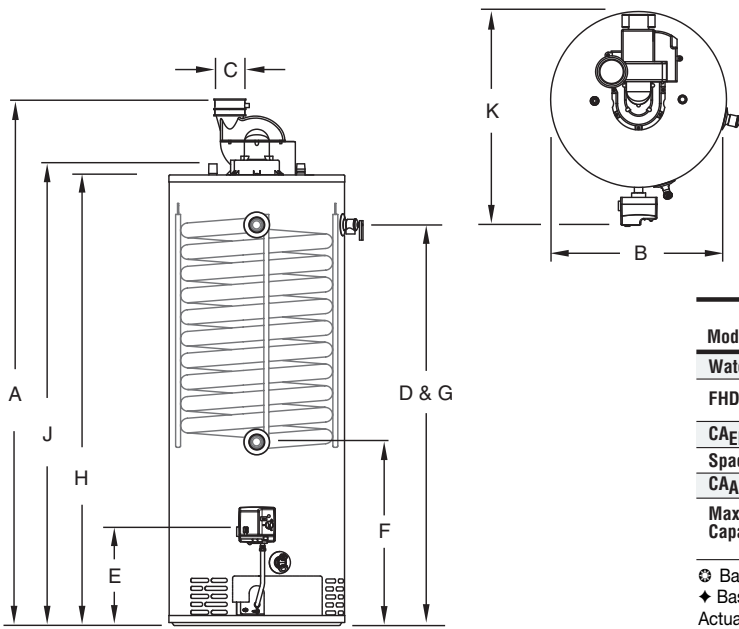

Note: (C-DW2-TW75 will not have a pedestal base)

Heat Exchanger Head Loss		C-DW2-TW50	3" Vent Pipe	4" Vent Pipe
GPM	Ft. of Hd. Loss	C-DW2-TW75		
2	trace	Max. Equivalent Length	†60 ft.	†180 ft.
5	0.4	Min. Equivalent Length	7 ft.	15 ft.
8	2.3	Number	1	55 ft.
10	4.6	of	2	50 ft.
12	6.9	90° Elbows	3	45 ft.

†For high altitude installations, consult the installation instructions.

Model Number	C-DW2-TW50T10		C-DW2-TW75T10	
	FBN	FCX	BN	CX
Water Heating ⊙				
FHD	105	98	135	133
	U.S. Gal.	U.S. Gal.	U.S. Gal.	U.S. Gal.
CA_{EF}	.65	.65	.64	.64
Space Heating				
CA_{AFUE}%	82.0	82.0	82.0	82.0
Max. Heating Capacity ⬆	55,000 BTU/Hr. (16.1 kW)		55,000 BTU/Hr. (16.1 kW)	

⊙ Based on ANSI Z-21.10.1 and 10.3 and DOE Test Methods.

⬆ Based on ANSI/ASHRAE 124 Standard.

Actual values may vary based on circulator flow rate, number of zones, water and space heating demands. Numbers subject to change.

All natural gas models meet SCAQMD Requirements.
Meets NAECA Requirements

General

All gas water heaters are certified at 300 PSI test pressure (2068 kPa) and 150 PSI working pressure (1034 kPa). All potable water and heat exchanger connections are 3/4" NPT (19mm) on 11" (203mm) centers. All gas connections 1/2" (13mm).

All models design certified by CSA International (formerly AGA/CGA), ANSI Z-21.10.1 and or 10.3 and peak performance rated.

Dimensions and specifications subject to change without notice in accordance with our policy of continuous product improvement.

Suitable for Water (Potable) Heating and Space Heating

Toxic chemicals, such as those used for boiler treatment, shall NEVER be introduced into the potable water side. The potable side of this unit may NEVER be connected to any existing heating system or component(s) previously used with a non-potable water heating appliance. The heat exchanger side of the unit may be used in space heating applications.



Ambler, PA

For U.S. and Canada field service, contact your professional installer or local Bradford White sales representative.

Sales 800-523-2931 • Fax 215-641-1670 / Technical Support 800-334-3393 • Fax 269-795-1089 • Warranty 800-531-2111 • Fax 269-795-1089

International: Telephone 215-641-9400 • Telefax 215-641-9750 / Fax on Demand 888-538-7833 / www.bradfordwhite.com

BRADFORD WHITE - CANADA INC. Sales / Technical Support 866-690-0961 / 905-238-0100 • Fax 905-238-0105 / www.bradfordwhitecanada.com

Count On Bradford White
For Everything Hot Water™

©2006, Bradford White Corporation. All rights reserved.